



CONCHA CEGA DONÉR | 158 MM

APLICAÇÃO:
ABSOLUTA®, ALUK 2.0®, ALUK 2.5®,
NOSTRA 25®, CÉLERE®, ECOLINE 2.5®,
HYDRO OFFICIAL®, IMPERIAL
2.5®, INOVA®, MEGA 20®, MEGA 25®,
SUPREMA®, SMART 2.0®, SP20®.

Setembro/2023 - REV.:01 Julho/2024

PERSPECTIVA:
(sem escala)

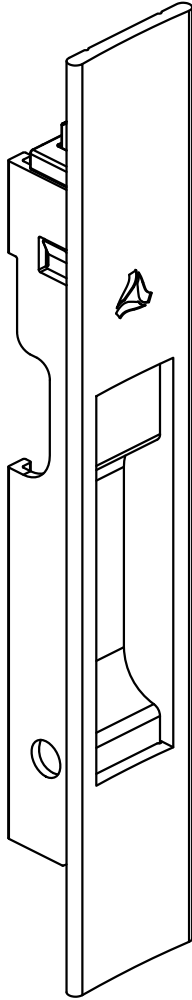

DIMENSÕES:
(escala 1:2)

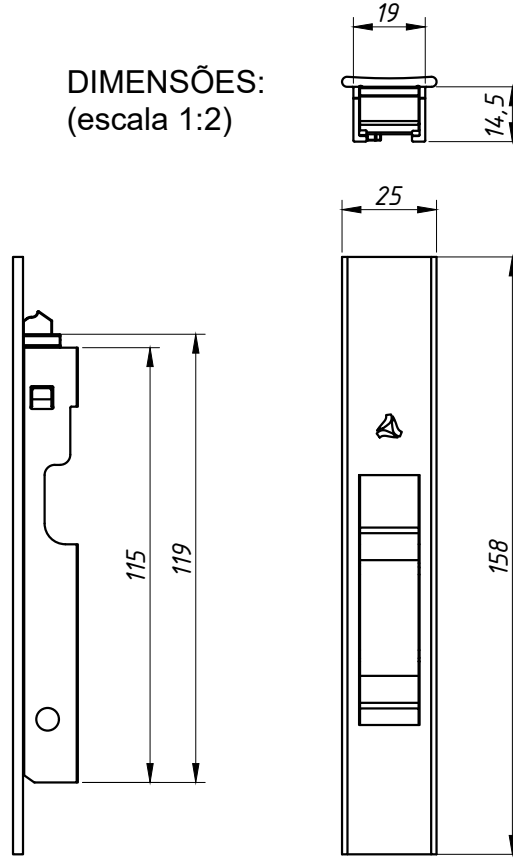

USINAGEM:
(escala 1:2)

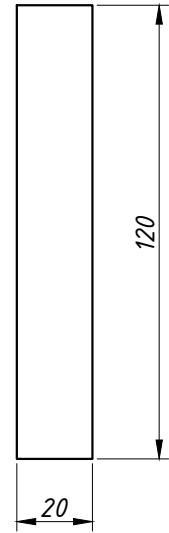

CARACTERÍSTICAS:

Componentes:	Matéria-prima:
Estrutura	Alumínio

Acabamento			
Preto	Fosco	Branco	Bronze

Embalagem	20 Conchas Cegas
-----------	------------------

DETALHE DE APLICAÇÃO

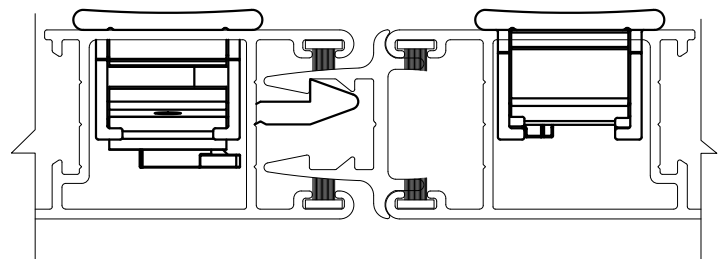

(escala 1:1)

ACABAMENTOS AMAIDEIRADOS CONSULTAR PÁGINA 04
NO CATÁLOGO TÉCNICO DE COMPONENTES.

CÓDIGO	ACABAMENTO
CON500PT	Preto
CON500FS	Fosco
CON500BC	Branco
CON500BZ	Bronze

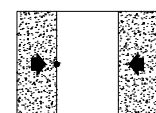

JANELAS
E PORTAS
DE CORRER